

AUTOCLEAR® 100100B

1.0m x 1.0m Raised Checked Bag X-ray For Explosives, Weapons, Narcotics & Duty Fraud



RealClear® reveals components of a gun, knife and bomb in real time, without lags and delays.



Available operator table and dual or LCD monitors (one 17" CRT is the normal configuration).

Control Screening is the leading worldwide producer of fast, reliable and sophisticated X-ray, Metal and Trace Detection screening systems. Visit us at www.controlscreening.com. Ask about our mobile and cargo systems. Our advanced systems and options are often integrated, leased or rented.

The AUTOCLEAR® 100100B (featuring a 1.0 m wide x 1.0 m high or 39.4" wide x 39.4" high tunnel opening), is a heavy-duty, conveyORIZED, X-ray scanner designed for screening cargo and large checked luggage, detecting concealed weapons, explosives, narcotics, currency, contraband or manifest fraud at:

**Airports • Seaports • Courts
Customs • Corporate Facilities
Government Buildings
Checkpoints • Loading Docks
Mailrooms • Border Crossings
Nuclear • Access Control
Special Events
Rail or Bus Stations
Police • Military Bases**

Features

- ➔ Raised conveyor for sharper, enlarged screen image and ease of examination.
- ➔ Heavy-duty, high capacity conveyor with easy changeouts. Available uphill extension conveyor and bag chute.
- ➔ Narrower footprint enhances security. Conveyor end folds up for transport.
- ➔ RealClear® function reveals components of dense items in realtime without lags or delays.
- ➔ Features Pentium 4, 17" monitor, Multi-Energy Color with Organic/Inorganic Stripping, RealClear®, autoDensAlert®, auto-Outline®, autoSensing®, autoCal®, Lighten, Help, DensityScan, and Low Density Stripping, among other features.
- ➔ TIP, Training and Image Archiving also available. autoMatalert®, option highlights suspect materials using atomic number and density.
- ➔ autoTracking® guided conveyor belt system never needs adjustment, lowering operating costs.
- ➔ autoSensing® eliminates the need for troublesome photosensors or footpad switch. Assures 100% screening of thin blades or plastique in courier envelopes or magazines, or of bag already in tunnel at start-up.
- ➔ Interactive training and highly responsive local service. Engineered, made and rigorously tested in the USA to ISO 9001 and regulatory standards.

Leading contraband threat detection & field support, since 1937

AUTOCLEAR®

autoclearus.com

Scintrex® • CheckGate® • Dynavision® • Control Screening® • Federal Labs®
U.S. Canada Europe Dubai Latin America Beijing Hong Kong Singapore

Model 100100B X-ray Specifications

Overall Dimensions: Inspection Capabilities

Tunnel Size:	314.2 cm (123.7") L x 129.3 cm (50.9") W x 192.9 cm (75.9") H
Material Penetration:	39.4" wide (100 cm) 39.4" wide (100 cm)
Contrast Sensitivity:	28-29 mm steel
Resolution:	Over 2 million color tones.
Conveyor:	40 AWG wire
Pulling Weight:	Speed: 48.0 feet per minute; 24 cm per second.
autoTracking®:	Reversible. Toggles for easy belt changeover.
Film Safety:	Load conveyor extension end folds up for freight elevator, and ease of transport.
	150 kg (331 lbs) standard; 403.2 kg (887 lbs) option
	Belt guaranteed to autoTrack for life.
	Guaranteed for high-speed films up to ISO 1600 (33 DIN).

***Full autoSensing® without photosensors, moving parts, or footpad.**

Reduces downtime and assures all magazines, envelopes or items are scanned, no matter how thin, or of bag already in tunnel at start-up. Enhances radiation safety.

X-ray Generator

X-ray tube head:	Self-contained, shielded tank
High voltage rating:	160 kV, 140 kV Operating Voltage
Duty cycle:	100% with sealed oil bath cooling
Beam orientation:	Diagonal (80° beam divergence)
Dose rate per exam:	0.1 mR. Lower doses available.

X-ray Detectors

Surface-mounted, multilayer, fully integrated, high frequency, solid state detectors using high-speed processors and advanced Pentium 4 signal processing with Multi-Energy.

Video

Standard with color 17" SVGA monitor. High resolution, flicker-free, .21 dot pitch, low rad. monitor, 1280 x 1024 video card. Multi-Energy color included with available second monitor or flat screen or larger monitor(s). Displays organics in orange and inorganics in blue, both overlapping in green and very dense objects in black.

Standard Features

- Multi-Energy organic and inorganic color & stripping
- RealClear®
- autoDensAlert®
- autoTracking®
- autoSensing®
- autoOutline®
- autoCal®
- Dark & Light enhance
- DensityScan
- Color; Reverse B/W
- High/Low Density & Stripping
- High density
- Help
- Fast (25 second) initial warm-up
- Fully functional, robust, low profile
- Reversible conveyor direction

Options

- autoMatalert®
- Threat Image Projection (TIP)
- Roller bed or conveyor extensions
- Tropical Humidity Kit
- Image Archiving
- CE mark
- Extra pulling power
- Locking metal keypad cover
- kV, mA meter or item counter
- LCD, dual or larger monitor(s)
- Footpad or optical on/off
- Variable height keypad mount
- Power conditioner, or UPS
- Table or locking monitor hood
- Remote operation; printer or VCR cable
- Built-in training
- Rentals or leases
- autoNet
- TipNet

Physical Details

Dimensions:	See Drawing
Approx. Weight:	1,600 lbs (726 kg) or 2,200 lbs (998 kg) (crated)
Construction:	Unibody heavy gauge epoxy-painted steel construction with stainless steel trim and accessories. Non-marring casters, leveling jackscrews, and reinforced forklift pockets. Corrosion-resistant command center keypad mounted on side, or available on table.
Environmental Conditions:	Temperature range: 32° to 104° F, (0° - 40° C), 95% non-condensing.
Electrical Power Requirements:	Consumption: 100, 110 volts AC ± 10% (<7.5 amps) 200, 220, 230, 240, 250 volts AC ± 10%, <3.75 amps. All at 50 or 60 Hz.

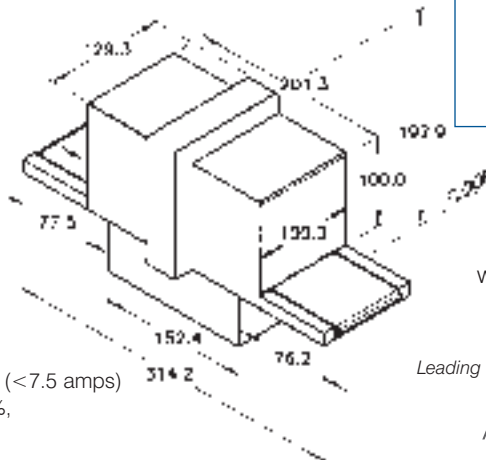

Dimensions are in centimeters
Note: Non-marring casters

www.autoclearus.com

Technology Labs & Headquarters Plant

2 Gardner Road
Fairfield, NJ 07004-2206 USA
Tel: 1 (973) 276-6161
Fax: 1 (973) 276-6162
info@autoclearus.com

Central EU

eu@autoclearus.com
Tel: + 33 2 38 61 97 00
Fax: + 33 2 38 61 97 01

Southern EU

seu@autoclearus.com

Northern EU

neu@autoclearus.com

Canada & Scintrex

info@scintrextrace.com
300 Parkdale Ave., Ottawa
Ontario, Canada K1Y 1G2
Tel: 1 (613) 224-1061
Fax: 1 (613) 224-2603

Asia Southeast & North

sasia@autoclearus.com
nasia@autoclearus.com
china@autoclearus.com

Latin America

latina@autoclearus.com

Middle East

ME@autoclearus.com
Dubai, UAE
Tel: + 971 6 557 4505
Fax: + 971 6 557 4507

Western U.S.

sw@autoclearus.com

Distributor:

ISO 9001-2000 Certified

www.autoclearus.com
www.scintrextrace.com www.fed-labs.com

Leading contraband threat detection & field support, since 1937



autoclearus.com

Scintrex® • CheckGate® • Dynavision® • Control Screening® • Federal Labs®
U.S. Canada Europe Dubai Latin America Beijing Hong Kong Singapore